

YE4系列三相异步电动机

YE4 series three-phase induction motors

YE4系列三相异步电动机是采用新材料、新工艺和优化设计而制造的全封闭、自扇冷鼠笼三相异步电动机。是新一代节能电动机。

YE4系列电动机中心从H80 - H355，功率从0.55KW - 315KW，级数为2、4、6、8级。

YE4系列电机防护等级为IP55，冷却方式IC411，安装尺寸符合IEC标准。额定电压为380V，额定频率50HZ。工作环境温度不超过40℃，海拔不超过1000米。工作方式：连续（S1）。

YE4系列超高效率三相异步电动机具有效率高，起动转矩大，噪声低，结构更加合理，冷却散热条件成熟，本系列电动机为一般用途的三相异步电动机，可用于驱动各种通用机械设备，如压缩机、风机、水泵等机械设备，也可在石油、化工、医药、矿山及其它（如环境使用条件特殊，请与设计人员联系）。

在YE4基本系列电动机基础上，也可制成YE4-W户外型、YE4-TH户内湿热带型、YE4-THW户外湿热带型。YE4-TA户内干热带型、YE4-TAW户外干热带型、YE4-F1户内中等腐蚀型、YE4-WF1户外中等腐蚀型、YE4-F2户内强腐蚀型及YE4-WF2户外强腐蚀型等气候环境条件。

该系列电动机效率指标符合GB18613-2020《中小型三相异步电动机能效限定值及能效等级》中规定的能效2级的效率值与IEC60034-30的IE4保持一致。

YE4 series three-phase asynchronous motors are fully enclosed and self-fan-cooled squirrel-cage three-phase asynchronous motors manufactured with new materials, new technology and optimized design. It's a new generation of energy-saving motors.

YE4 series motor center from H80-H355, power from 0.55KW-315KW, series of 2, 4, 6, 8.

YE4 series motor protection level is IP55, cooling mode IC411, installation scale in line with IEC standards. Rated voltage 380V, rated frequency 50HZ. The working ambient temperature is not more than 40℃, and the altitude is not more than 1000 meters. Working mode: Continuous (S1).

YE4 series ultra-high efficiency three-phase asynchronous motor has high efficiency, large starting torque, low noise, more reasonable structure, mature cooling and heat dissipation conditions, this series of motor is a general purpose three-phase asynchronous motor, can be used to drive a variety of general mechanical equipment, such as compressors, fans, water pumps and other mechanical equipment. It can also be used in petroleum, chemical, pharmaceutical, mining and other (if the environmental conditions are special, please contact the designer).

On the basis of YE4 basic series motor, it can also be made into YE4-W outdoor type, YE4-TH indoor wet heat belt type, YE4-THW outdoor wet heat belt type. YE4-TA indoor dry hot zone type, YE4-TAW outdoor dry tropical type, YE4-F1 indoor medium corrosion type, YE4-WF1 outdoor medium corrosion type, YE4-F2 indoor strong corrosion type and YE4-WF2 outdoor strong corrosion type and other climatic and environmental conditions.

The efficiency index of this series of motors conforms to the efficiency value of energy efficiency level 2 stipulated in GB18613-2020 "Energy Efficiency Limits and energy efficiency grades of Small and medium-sized three-phase asynchronous Motors" and is consistent with IE4 of IEC60034-30.

型号含义

Meaning of type code

产品型号按下列顺序排列：



安装型式

MOUNTING ARRANGEMENTS

五种基本结构型式

- B3: 机座带底脚，端盖无凸缘的结构型式。
- B5: 机座不带底脚，端盖上有凸缘（带通孔）的结构型式。
- B35: 机座带底脚，端盖上有凸缘（带通孔）的结构型式。
- B34: 机座带底脚，端盖上有凸缘（带螺孔）的结构型式。
- B14: 机座不带底脚，端盖上有凸缘（带螺孔）的结构型式。

- THERE ARE FIVE BASIC CONSTRUCTIONAL MOUNTING ARRANGEMENTS FOR SERIES Y2 MOTORS:
- B3: FRAME WITH FEET, END BRACKET WITHOUT FLANGE.
 - B5: FRAME WITHOUT FEET, END BRACKET WITH FLANGE (WITH HOLES)
 - B35: FRAME WITH FEET, END BRACKET WITH FLANGE (WITH HOLES)
 - B34: FRAME WITH FEET, END BRACKET WITH FLANGE (WITH SCREW HOLES)
 - B14: FRAME WITHOUT FEET, END BRACKET WITH FLANGE (WITH SCREW HOLES)

常用的安装型式，以及适用的机座号见表2： THE COMMONLY USED MOUNTING ARRANGEMENTS AND THE CORRESPONDING FRAME NUMBERS ARE SHOWN IN TABLE2:

表2 TABLE 2:

基本结构形式 Basic	B3						B34	B14			B5			B35		
安装形式 Code	B3	B6	B7	B8	V5	V6	B34	B14	V18	B5	V1	V3	B35	V15	V36	
示意图 Sketch																
中心高 Range of frame	80-355		80-160				80-112			80-280		80-355	80-160	80-355		80-160

轴 承

BEARINGS

电动机轴承号见表3： THE BEARING NO. FOR MOTORS ARE AS SHOWN IN TABLE3:

表3 TABLE 3:

机座号 Frame No.	轴伸端 Driving end				非轴伸端 Non-driving end			
	2极 2 Poles	4.6.8极 4.6.8 Poles	2极 2 Poles	4.6.8极 4.6.8 Poles	2极 2 Poles	4.6.8极 4.6.8 Poles	2极 2 Poles	4.6.8极 4.6.8 Poles
80	6204-2RS/C3				6204-2RS/C3			
90	6205-2RS/C3				6205-2RS/C3			
100	6206-2RS/C3				6206-2RS/C3			
112	6306-2RS/C3				6306-2RS/C3			
132	6308-2RS/C3				6308-2RS/C3			
160	6309/C3				6309/C3			
180	6311/C3				6311/C3			
200	6312/C3				6312/C3			
225	6313/C3	6313/C3	6313/C3	6312/C3	6313/C3	6313/C3	6313/C3	6313/C3
250	6313/C3	6314/C3	6313/C3	6313/C3	6313/C3	6313/C3	6313/C3	6313/C3
280	6314/C3	6317/C3	6314/C3	6314/C3	6314/C3	6314/C3	6314/C3	6314/C3
315	6317/C3	6319/C3	6317/C3	6319/C3	6317/C3	6317/C3	6317/C3	6319/C3
355	6319/C3	6322/C3	6319/C3	6322/C3	6319/C3	6319/C3	6319/C3	6322/C3

振 动

VIBRATION

电动机在空载时测得速度的有效值 (即振动烈度限值) 不超过表4中所列数值。

Valid values measured motor at no-load speed (i.e. vibration limit value) does not exceed the table values listed in 4.

表4 TABLE 4:

机座号 Frame No.	≤132			>132~225			>225~355		
	位移 Displacement μm	速度 Speed mm/s	加速度 Acceleration m/s ²	位移 Displacement μm	速度 Speed mm/s	加速度 Acceleration m/s ²	位移 Displacement μm	速度 Speed mm/s	加速度 Acceleration m/s ²
安装方式 Installation									
自由悬置 Free suspension	25	1.6	2.5	35	2.2	3.5	45	2.8	4.4
刚性安装 Rigid mounting	21	1.3	2.0	29	1.8	2.8	37	2.3	3.6

接 线 盒

TERMINAL BOX

从轴伸端视之, 接线盒位于机座顶部, 用户有特殊要求时也可装在左面或右侧。电源电缆从接线盒上的出线孔引出, 在出线口处有密封结构(详见图)。

THE NORMAL POSITION OF THE TERMINAL BOX IS ON THE TOP SIDE WHEN LOOKING AT THE DRIVING END OF THE MOTOR, BUT MAY BE ARRANGED ON THE LEFT-HAND SIDE OR ON THE RIGHT-HAND IF SPECIFIED WHEN ORDERING. THE POWER CABLE CAN BE LED OUT THROUGH THE OUTLET OF THE TERMINAL BOX IN FOUR DIRECTIONS, THERE IS A SEALING CONSTRUCTION AT THE OUTLET (FOR DETAILS, SEE FIGURE)

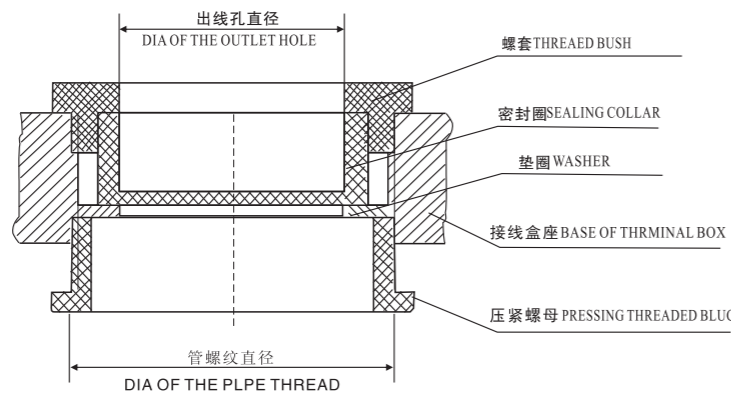

各种机座号的管螺纹直径和出线孔直径如表5: THE DIAMETERS OF THE OUTLET HOLES AND THE PIPE THREADS FOR THE FRAME NUMBERS ARE AS SHOWN IN TABLES:

表5 TABLE 5:

机座号 Frame No.	进线口数 Number of entry	进线口螺纹 Thread of conduit entry	进线电缆最大外径 The max. outer Diameter of inlet cable
YE4-80~100	1	M20×1.5	φ14
YE4-112~132	2	M25×1.5	φ18
YE4-160~180	2	M40×1.5	φ32
YE4-200~225	2	M50×1.5	φ38
YE4-250~280	2	M63×1.5	φ44
YE4-280~315	2	M63×1.5	φ44

技术参数 TECHNICAL DATA
SPEED 3000RPM 2-POLE 50HZ

型号 Type	功率 Output		转速 Speed r/min	电流 In A		频率 Frequency HZ	效率 Efficiency η%	功率因数 Power factor CosΦ	额定转矩 T _N N·m	堵转转矩	最大转矩	堵转电流	惯量 Moment (J) kgm ²	噪声 Noise LwdB(A)
	kW	HP		380V	400V					T _{st} T _N	T _{max} T _N	I _{st} I _N		
YE4-80M1-2P	0.75	1.1	2815	1.64	1.56	50	83.5	0.83	2.5	2.2	2.3	8.5	0.0013	62
YE4-80M2-2P	1.1	1.5	2890	2.4	2.2	50	85.2	0.83	3.6	2.2	2.3	8.5	0.0017	62
YE4-90S-2P	1.5	2	2900	3.1	2.9	50	86.5	0.85	4.9	2.2	2.3	9	0.0024	67
YE4-90L-2P	2.2	3	2900	4.4	4.2	50	88	0.86	7.2	2.2	2.3	9	0.0033	67
YE4-100L-2P	3	4	2900	5.9	5.6	50	89.1	0.87	9.9	2.2	2.3	9.5	0.0052	74
YE4-112M-2P	4	5.5	2915	7.7	7.3	50	90	0.88	13.1	2.2	2.3	9.5	0.009	77
YE4-132S1-2P	5.5	7.5	2945	10.4	9.9	50	90.9	0.88	17.8	2	2.3	9.5	0.026	79
YE4-132S2-2P	7.5	10	2945	14.0	13.3	50	91.7	0.89	24.3	2	2.3	9.5	0.0322	79
YE4-160M1-2P	11	15	2955	20.3	19.3	50	92.6	0.89	35.5	2	2.3	9.5	0.0649	81
YE4-160M2-2P	15	20	2955	27.4	26.1	50	93.3	0.89	48.5	2	2.3	9.5	0.0795	81
YE4-160L-2P	18.5	25	2955	33.7	32.0	50	93.7	0.89	59.8	2	2.3	9.5	0.0962	81
YE4-180M-2P	22	30	2970	40.0	38.0	50	94	0.89	70.7	2	2.3	9.5	0.1494	83
YE4-200L1-2P	30	40	2970	54.2	51.5	50	94.5	0.89	96.5	2	2.3	9	0.2436	84
YE4-200L2-2P	37	50	2970	66.6	63.3	50	94.8	0.89	119.0	2	2.3	9	0.2784	84
YE4-225M-2P	45	60	2975	80.9	76.8	50	95	0.89	144.5	2	2.3	9	0.364	86
YE4-250M-2P	55	75	2985	98.5	93.6	50	95.3	0.89	176.0	2	2.3	9	0.9654	89
YE4-280S-2P	75	100	2980	133.9	127.2	50	95.6	0.89	240.4	1.8	2.3	8.5	1.148	91
YE4-280M-2P	90	125	2980	160.4	152.4	50	95.8	0.89	288.4	1.8	2.3	8.5	1.3632	91
YE4-315S-2P	110	150	2985	195.6	185.8	50	96	0.89	351.9	1.8	2.3	8.5	1.8792	92
YE4-315M-2P	132	180	2985	234.2	222.5	50	96.2	0.89	422.3	1.8	2.3	8.5	2.1728	92
YE4-315L1-2P	160	220	2985	283.6	269.5	50	96.3	0.89	511.9	1.8	2.2	8.5	2.5252	92
YE4-315L2-2P	200	270	2985	353.8	336.1	50	96.5	0.89	639.9	1.8	2.2	8.5	3.0537	92
YE4-355M-2P	250	340	2985	432.5	410.9	50	96.5	0.91	799.8	1.6	2.2	8.5	4.1448	97
YE4-355L-2P	315	430	2985	545.0	517.8	50	96.5	0.91	1007.8	1.6	2.2	8.5	5.222	97

技术参数 TECHNICAL DATA
SPEED 1500RPM 4-POLE 50HZ

型号 Type	功率 Output		转速 Speed r/min	电流 In A		频率 Frequency HZ	效率 Efficiency η %	功率因数 Power factor CosΦ	额定转矩 TN N·m	堵转转矩	最大转矩	堵转电流	惯量 Moment (J) kgm ²	噪声 Noise LwdB(A)
	kW	HP		额定转矩	额定转矩					额定电流				
				Tst TN	Tmax TN					Ist IN				
YE4-80M2-4P	0.75	1.1	1435	1.8	1.7	50	85.7	0.74	5.0	2.3	2.3	8.5	0.0024	56
YE4-90S-4P	1.1	1.5	1445	2.6	2.4	50	87.2	0.75	7.3	2.3	2.3	8.5	0.0045	59
YE4-90L-4P	1.5	2	1445	3.4	3.2	50	88.2	0.76	9.9	2.3	2.3	9.0	0.0061	59
YE4-100L1-4P	2.2	3	1460	4.7	4.5	50	89.5	0.79	14.4	2.3	2.3	9.0	0.0123	64
YE4-100L2-4P	3	4	1460	6.3	6.0	50	90.4	0.80	19.6	2.3	2.3	9.5	0.0172	64
YE4-112M-4P	4	5.5	1460	8.3	7.9	50	91	0.80	26.2	2.3	2.3	9.5	0.0222	65
YE4-132S-4P	5.5	7.5	1475	11.4	10.8	50	91.9	0.80	35.6	2.0	2.3	9.5	0.0586	71
YE4-132M-4P	7.5	10	1475	15.2	14.4	50	92.6	0.81	48.6	2.0	2.3	9.5	0.069	71
YE4-160M-4P	11	15	1475	21.6	20.5	50	93.3	0.83	71.2	2.0	2.3	9.5	0.136	73
YE4-160L-4P	15	20	1475	28.9	27.4	50	93.9	0.84	97.1	2.0	2.3	9.5	0.173	73
YE4-180M-4P	18.5	25	1480	35.1	33.3	50	94.2	0.85	119.4	2.0	2.3	9.5	0.2465	76
YE4-180L-4P	22	30	1480	41.6	39.5	50	94.5	0.85	142.0	2.0	2.3	9.5	0.2817	76
YE4-200L-4P	30	40	1485	56.5	53.6	50	94.9	0.85	192.9	2.0	2.3	9.0	0.5275	76
YE4-225S-4P	37	50	1485	69.5	66.0	50	95.2	0.85	237.9	2.0	2.3	9.0	0.7363	78
YE4-225M-4P	45	60	1485	84.3	80.1	50	95.4	0.85	289.4	2.0	2.3	9.0	0.8071	78
YE4-250M-4P	55	75	1485	101.5	96.4	50	95.7	0.86	353.7	2.0	2.3	9.0	1.3369	79
YE4-280S-4P	75	100	1490	136.4	129.6	50	96	0.87	480.7	2.0	2.3	8.5	1.963	80
YE4-280M-4P	90	125	1490	161.7	153.5	50	96.1	0.88	576.8	2.0	2.3	8.5	2.1771	80
YE4-315S-4P	110	150	1490	195.0	185.2	50	96.3	0.89	705.0	1.8	2.2	8.5	3.6446	88
YE4-315M-4P	132	180	1490	233.8	222.1	50	96.4	0.89	846.0	1.8	2.2	8.5	4.1342	88
YE4-315L1-4P	160	220	1490	279.6	265.6	50	96.6	0.90	1025.5	1.8	2.2	8.5	4.8958	88
YE4-315L2-4P	200	270	1490	349.2	331.7	50	96.7	0.90	1281.9	1.8	2.2	8.5	5.8749	92
YE4-355M-4P	250	340	1490	436.4	414.6	50	96.7	0.90	1602.3	1.8	2.2	8.5	10.5792	92
YE4-355L-4P	315	430	1490	549.9	522.4	50	96.7	0.90	2019.0	1.8	2.2	8.5	12.064	92

技术参数 TECHNICAL DATA
SPEED 1000RPM 6-POLE 50HZ

型号 Type	功率 Output		转速 Speed r/min	电流 In A		频率 Frequency HZ	效率 Efficiency η %	功率因数 Power factor CosΦ	额定转矩 TN N·m	堵转转矩	最大转矩	堵转电流	惯量 Moment (J) kgm ²	噪声 Noise LwdB(A)
	kW	HP		额定转矩	额定转矩					额定电流				
				Tst TN	Tmax TN					Ist IN				
YE4-90S-6P	0.75	1.1	955	2.0	1.9	50	83.1	0.70	7.5	2.1	2.1	7.5	0.0057	57
YE4-90L-6P	1.1	1.5	955	2.8	2.7	50	84.1	0.70	11.0	2.1	2.1	7.5	0.0083	57
YE4-100L-6P	1.5	2	960	3.7	3.5	50	86.2	0.71	14.9	2.1	2.1	7.5	0.0159	61
YE4-112M-6P	2.2	3	970	5.4	5.1	50	87.1	0.71	21.7	2.1	2.1	7.5	0.0286	65
YE4-132S-6P	3	4	975	7.2	6.9	50	88.7	0.71	29.4	2.0	2.1	7.5	0.0457	69
YE4-132M1-6P	4	5.5	975	9.4	8.9	50	89.7	0.72	39.2	2.0	2.1	8.0	0.0564	69
YE4-132M2-6P	5.5	7.5	975	13.0	12.3	50	89.5	0.72	53.9	2.0	2.1	8.0	0.0806	69
YE4-160M-6P	7.5	10	980	16.6	15.8	50	90.2	0.76	73.1	2.0	2.1	8.0	0.1401	73
YE4-160L-6P	11	15	980	23.7	22.5	50	91.5	0.77	107.2	2.0	2.1	8.5	0.2081	73
YE4-180L-6P	15	20	985	30.8	29.3	50	92.5	0.80	145.4	2.0	2.1	8.5	0.3384	73
YE4-200L1-6P	18.5	25	985	37.7	35.9	50	93.1	0.80	179.4	2.0	2.1	8.5	0.433	73
YE4-200L2-6P	22	30	985	43.9	41.7	50	93.9	0.81	213.3	2.0	2.1	8.5	0.5292	73
YE4-225M-6P	30	40	985	58.9	56.0	50	94.3	0.82	290.9	2.0	2.1	8.3	0.8085	74
YE4-250M-6P	37	50	990	71.6	68.0	50	94.6	0.83	356.9	2.0	2.1	8.3	1.5204	76
YE4-280S-6P	45	60	990	86.8	82.5	50	94.9	0.83	434.1	2.0	2.0	8.5	2.1302	78
YE4-280M-6P	55	75	990	104.5	99.3	50	95.2	0.84	530.6	2.0	2.0	8.5	2.4757	78
YE4-315S-6P	75	100	990	142.2	135.1	50	95.4	0.84	723.5	1.6	2.0	8.0	4.0861	83
YE4-315M-6P	90	125	990	168.3	159.9	50	95.6	0.85	868.2	1.6	2.0	8.0	4.8746	83
YE4-315L1-6P	110	150	990	205.7	195.4	50	95.6	0.85	1061.1	1.6	2.0	8.0	5.8782	83
YE4-315L2-6P	132	180	990	243.4	231.3	50	95.8	0.86	1273.3	1.6	2.0	8.0	7.0252	83
YE4-355M1-6P	160	220	990	294.4	279.7	50	96	0.86	1543.4	1.6	2.0	8.0	11.1414	85
YE4-355M2-6P	200	270	990	367.7	349.3	50	96.1	0.86	1929.3	1.6	2.0	8.0	13.9627	85
YE4-355L-6P	250	340	990	459.6	436.6	50	96.1	0.86	2411.6	1.6	2.0	8.0	15.7837	85

技术参数 TECHNICAL DATA
SPEED 750RPM 8-POLE 50HZ

型号 Type	功率 Output		转速 Speed r/min	电流 In A		频率 Frequency HZ	效率 Efficiency η %	功率因数 Power factor Cos Φ	额定转矩 T _N N·m	堵转转矩	最大转矩	堵转电流	惯量 (J) kgm ²	噪声 Noise LwdB(A)
	kW	HP		380V	400V					T _{st} T _N	T _{max} T _N	I _{st} I _N		
YE4-100L1-8P	0.75	1.5	705	2.2	2.1	50	78.4	0.66	10.2	2.0	2.0	7.0	0.0092	59
YE4-100L2-8P	1.1	2	705	3.1	2.9	50	80.8	0.67	14.9	2.0	2.0	7.0	0.0141	59
YE4-112M-8P	1.5	3	705	4.0	3.8	50	82.6	0.69	20.3	1.8	2.0	7.0	0.0209	61
YE4-132S-8P	2.2	4	720	5.7	5.4	50	84.5	0.70	29.2	1.8	2.0	7.5	0.0457	64
YE4-132M-8P	3	5.5	720	7.6	7.2	50	85.9	0.70	39.8	1.8	2.0	7.8	0.0591	64
YE4-160M1-8P	4	7.5	725	9.8	9.3	50	87.1	0.71	52.7	1.8	2.0	7.9	0.0849	68
YE4-160M2-8P	5.5	10	725	13.1	12.5	50	88.3	0.72	72.4	1.8	2.0	8.1	0.1104	68
YE4-160L-8P	7.5	15	725	17.2	16.4	50	89.3	0.74	98.8	1.8	2.0	7.8	0.1614	68
YE4-180L-8P	11	20	735	25.0	23.7	50	90.4	0.74	142.9	1.8	2.0	7.9	0.2679	70
YE4-200L-8P	15	25	735	33.3	31.7	50	91.2	0.75	194.9	1.8	2.0	8.0	0.3849	73
YE4-225S-8P	18.5	30	735	40.9	38.8	50	91.7	0.75	240.4	1.8	2.0	8.1	0.6427	73
YE4-225M-8P	22	40	735	47.8	45.4	50	92.1	0.76	285.9	1.8	2.0	8.3	0.7671	73
YE4-250M-8P	30	50	740	63.9	60.7	50	92.7	0.77	387.2	1.8	2.0	7.9	1.2924	75
YE4-280S-8P	37	60	740	77.4	73.5	50	93.1	0.78	477.5	1.8	2.0	7.9	1.9575	76
YE4-280M-8P	45	75	740	93.8	89.2	50	93.4	0.78	580.7	1.8	2.0	7.9	2.4181	76
YE4-315S-8P	55	100	740	111.5	105.9	50	93.7	0.80	709.8	1.6	2.0	8.2	3.8577	82
YE4-315M-8P	75	125	740	151.2	143.6	50	94.2	0.80	967.9	1.6	2.0	7.6	5.1995	82
YE4-315L1-8P	90	150	740	178.8	169.9	50	94.4	0.81	1161.5	1.6	2.0	7.7	6.2058	82
YE4-315L2-8P	110	180	740	217.9	207.0	50	94.7	0.81	1419.6	1.6	2.0	7.7	7.7992	82
YE4-355M1-8P	132	220	745	260.9	247.9	50	94.9	0.81	1692.1	1.6	2.0	7.7	12.7935	89
YE4-355M2-8P	160	270	745	311.7	296.1	50	95.1	0.82	2051.0	1.6	2.0	7.7	15.6365	89
YE4-355L-8P	200	340	745	388.4	369.0	50	95.4	0.82	2563.8	1.6	2.0	7.8	18.4796	89
YE4-315S-10P	45	75	590	99.6	94.6	50	91.5	0.75	728.4	1.5	2.0	6.2	3.79	82
YE4-315M-10P	55	100	590	121.1	115.1	50	92	0.75	890.3	1.5	2.0	6.2	4.62	82
YE4-315L1-10P	75	125	590	162.1	154.0	50	92.5	0.76	1214.0	1.5	2.0	6.2	6.19	82
YE4-315L2-10P	90	150	590	191.0	181.4	50	93	0.77	1456.8	1.5	2.0	6.2	7.26	82
YE4-355M1-10P	110	180	590	229.9	218.4	50	93.2	0.78	1780.5	1.3	2.0	6	10.61	90
YE4-355M2-10P	132	220	590	275.0	261.2	50	93.5	0.78	2136.6	1.3	2.0	6	12.7	90
YE4-355L-10P	160	270	590	333.3	316.7	50	93.5	0.78	2589.8	1.3	2.0	6	15.64	90

安装及外形尺寸 MOUNTING AND OVERALL DIMENSIONS

IM B3 H80-355

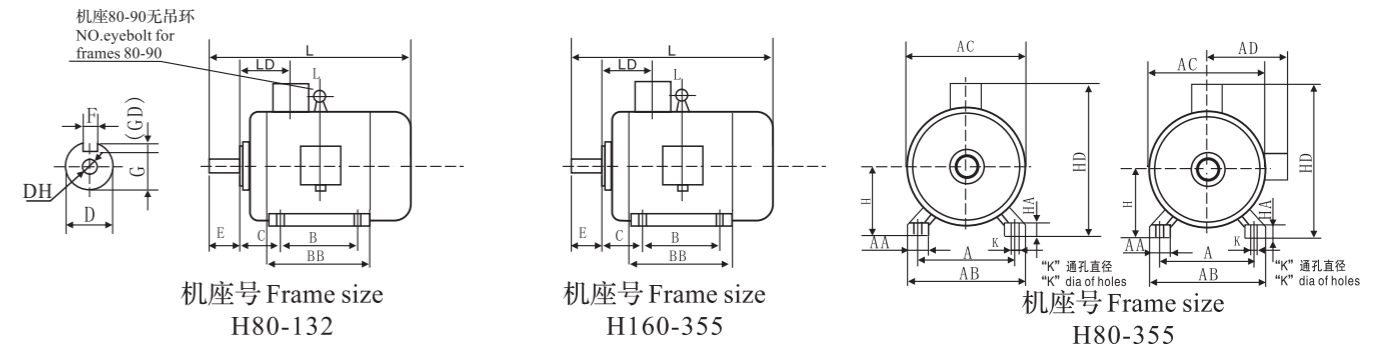

型号 Type	极数 Poles	尺寸 Dimensions in mm																		
		A	AA	B	C	D*	E	F	G	H	K	AB	AC	AD	HD	L	BB	HA	LD	(DH)*
YE4-80	2, 4, 6, 8	125	34	100	50	19	40	6	15.5	80	10	165	167	165	245	300	131	10	74	M6×16
YE4-90S	2, 4, 6, 8	140	36	100	56	24	50	8	20	90	10	180	190	175	265	355	140	12	76	M8×19
YE4-90L	2, 4, 6, 8	140	36	125	56	24	50	8	20	90	10	180	190	175	265	385	165	12	76	M8×19
YE4-100L	2, 4, 6, 8	160	40	140	63	28	60	8	24	100	12	205	215	200	280	435	178	14	83	M10×22
YE4-112M	2, 4, 6, 8	190	45	140	70	28	60	8	24	112	12	230	255	223	335	520	185	15	87	M10×22
YE4-132S	2, 4, 6, 8	216	55	140	89	38	80	10	33	132	12	270	320	253	385	510	220	18	102	M12×28
YE4-132M	2, 4, 6, 8	216	55	178	89	38	80	10	33	132	12	270	320	253	385	540	290	18	102	M12×28
YE4-160M	2, 4, 6, 8	254	65	210	108	42	110	12	37	160	14.5	320	350	285	445	670	260	20	146	M16×36
YE4-160L	2, 4, 6, 8	254	65	254	108	42	110	12	37	160	14.5	320	350	285	445	710	300	20	146	M16×36
YE4-180M	2, 4, 6, 8	279	70	241	121	48	110	14	42.5	180	14.5	355	390	295	475	735	310	22	161	M16×36
YE4-180L	2, 4, 6, 8	279	70	279	121	48	110	14	42.5	180	14.5	355	390	295	475	770	345	22	161	M16×36
YE4-200L	2, 4, 6, 8	318	70	305	133	55	110	16	49	200	18.5	395	450	340	540	870	365	25	186	M20×42
YE4-225S	4, 6, 8	356	75	286	149	60	140	18	53	225	18.5	435	510	370	595	890	370	28	189	M20×42
YE4-225M	4, 6, 8	356	75	311	149	55	110	16	49	225	18.5	435	510	370	595	895	390	28	189	M20×42
YE4-250M	2	406	80	349	168	60	140	18	53	250	24	490	565	405	655	985	450	30	207	M20×42
YE4-250M	4, 6, 8	406	80	349	168	65	140	18	58	250	24	490	565	405	655	985	450	30	207	M20×42
YE4-280S	2	457	85	368	190	65	140	18	58	280	24	550	635	445	725	995	480	35	215	M20×42
YE4-280S	4	457	85	368	190	75	140	20	67.5	280	24	550	635	445	725	985	480	35	215	M20×42
YE4-280S	6, 8	457	85	368	190	75	140	20	67.5	280	24	550	635	445	725	995	480	35	215	M20×42
YE4-280M	2	457	85	419	190	65	140	18	58	280	24	550	635	445	725	1035	540	35	215	M20×42
YE4-280M	4	457	85	419	190	75	140	20	67.5	280	24	550	635	445	725	1035	540	35	215	M20×42
YE4-280M	6, 8	457	85	419	190	75	140	20	67.5	280	24	550	635	445	725	1035	540	35	215	M20×42
YE4-315S	2	508	120	406	216	65	140	18	58	315	28	630	645	535	850	1200	580	45	257	M20×42
YE4-315S	4, 6, 8, 10	508	120	406	216	80	170	22	71	315	28	630	645	535	850	1310	680	45	257	M20×42
YE4-315M	2	508	120	457	216	65	140	18	58	315	28	630	645	535	850	1310	680	45	257	M20×42
YE4-315M	4, 6, 8, 10	508	120	457	216	80	170	22	71	315	28	630	645	535	850	1340	680	45	257	M20×42
YE4-315L1	2	508	120	508	216	65	140	18	58	315	28	630	645	535	850	1310	680	45	257	M20×42
YE4-315L1	4, 6, 8, 10	508	120	508	216	80	170	22	71	315	28	630	645	535	850	1340	680	45	257	M20×42
YE4-315L2	2	508	120	508	216	65	140	18	58	315	28	630	645	535	850	1460	830	45	257	M20×42
YE4-315L2	6	508	120	508	216	80	170	22	71	315	28	630	645	535	850	1460	830	45	257	M20×42
YE4-315L2	4, 8, 10	508	120	508	216	80	170	22	71	315	28	630	645	535	850	1460	830	45	257	M20×42
YE4-355M	2	610	120	560	254	75	140	20	67.5	355	28	730	720	645	930	1505	760	52	284	M24×47
YE4-355M	4, 6, 8, 10	610	120	560	254	95	170	25	86	355	28	730	720	645	930	1535	760	52	284	M24×47
YE4-355L	2	610	120	630	254	75	140	20	67.5	355	28	730	720	645	930	1715	760	52	284	M24×47
YE4-355L	4, 6, 8, 10	610	120	630	254	95	170	25	86	355	28	730	720	645	930	1745	760	52	284	M24×47

注：1) DH尺寸只有出口电机要求，国内用户应按订货要求进行配制。
2) D尺寸公差：φ19-28为j6；φ38-48为K6；φ55-80为m6；φ95为m6。
Notes: 1) DH dimension is only required for exported motor. For domestic customers, it should be prepared according to the order requirement.
2) Tolerance for D dimension: j6 for φ19-28; K6 for φ38-48; m6 for φ55-80; m6 for φ95.

安装及外形尺寸 MOUNTING AND OVERALL DIMENSIONS
IM B35 H80-355

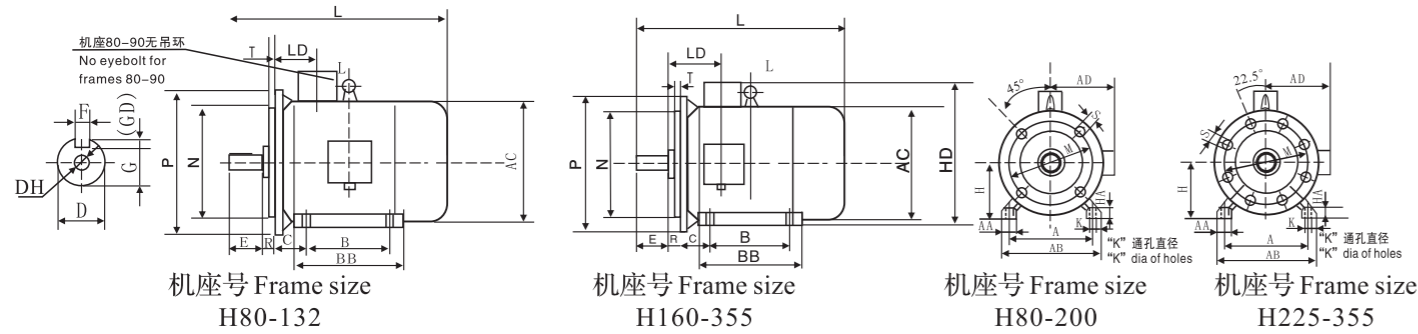

安装及外形尺寸 MOUNTING AND OVERALL DIMENSIONS

IMB5 H80-280

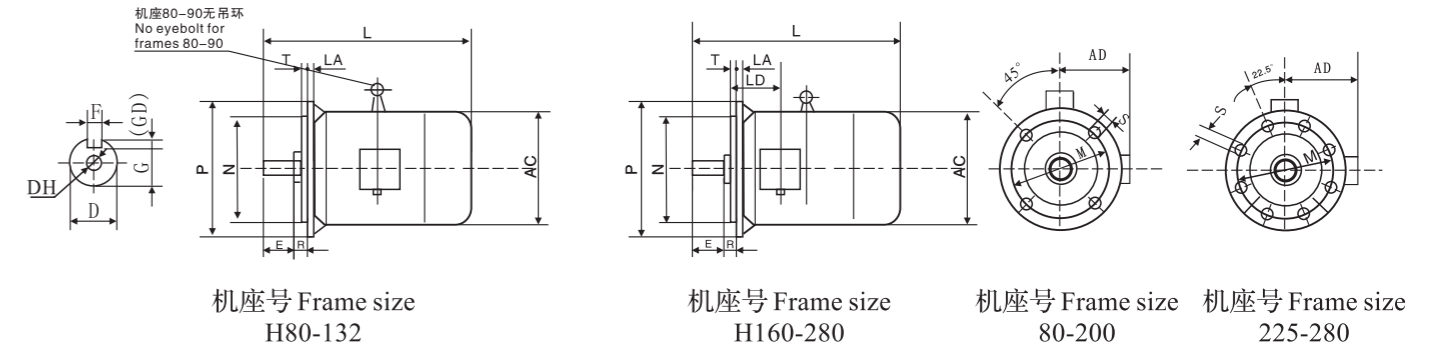

型号 Type	凸缘号 Flange NO.	极数 Poles	尺寸 Dimensions in mm																									
			A	AA	B	C	D*	E	F	G	H	K	AB	AC	AD	HD	L	BB	HA	LD	凸缘孔数 Flange holes	M	N*	P	R*	S	T	(DH)*
YE4-80	FF165	2, 4, 6, 8	125	34	100	50	19	40	6	15.5	80	10	165	167	165	245	300	131	10	74	4	165	130	200	0	12	3.5	M6×16
YE4-90S	FF165	2, 4, 6, 8	140	36	100	56	24	50	8	20	90	10	180	190	175	265	355	140	12	76	4	165	130	200	0	12	3.5	M8×19
YE4-90L	FF165	2, 4, 6, 8	140	36	125	56	24	50	8	20	90	10	180	190	175	265	385	165	12	76	4	165	130	200	0	12	3.5	M8×19
YE4-100L	FF215	2, 4, 6, 8	160	40	140	63	28	60	8	24	100	12	205	215	200	280	435	128	14	83	4	215	180	250	0	14.5	4	M10×22
YE4-112M	FF215	2, 4, 6, 8	190	45	140	70	28	60	8	24	112	12	230	255	223	335	520	185	15	87	4	215	180	250	0	14.5	4	M10×22
YE4-132S	FF265	2, 4, 6, 8	216	55	140	89	38	80	10	33	132	12	270	320	253	385	510	220	18	102	4	265	230	300	0	14.5	4	M12×28
YE4-132M	FF265	2, 4, 6, 8	216	55	178	89	38	80	10	33	132	12	270	320	253	385	540	290	18	102	4	265	230	300	0	14.5	4	M12×28
YE4-160M	FF300	2, 4, 6, 8	254	65	210	108	42	110	12	37	160	14.5	320	350	285	445	670	260	20	146	4	300	250	350	0	18.5	5	M16×36
YE4-160L	FF300	2, 4, 6, 8	254	65	254	108	42	110	12	37	160	14.5	320	350	285	445	710	300	20	146	4	300	250	350	0	18.5	5	M16×36
YE4-180M	FF300	2, 4, 6, 8	279	70	241	121	48	110	14	42.5	180	14.5	355	390	295	475	735	310	22	161	4	300	250	350	0	18.5	5	M16×36
YE4-180L	FF300	2, 4, 6, 8	279	70	279	121	48	110	14	42.5	180	14.5	355	390	295	475	770	345	22	161	4	300	250	350	0	18.5	5	M16×36
YE4-200L	FF350	2, 4, 6, 8	318	70	305	133	55	110	16	49	200	18.5	395	450	340	540	870	365	25	186	4	350	300	400	0	18.5	5	M20×42
YE4-225S	FF400	4, 6, 8	356	75	286	149	60	140	18	53	225	18.5	435	510	370	595	890	370	28	189	8	400	350	450	0	18.5	5	M20×42
YE4-225M	FF400	2	356	75	311	149	55	110	16	49	225	18.5	435	510	370	595	895	390	28	189	8	400	350	450	0	18.5	5	M20×42
YE4-250M	FF500	2	406	80	349	168	60	140	18	53	250	24	490	565	405	655	985	450	30	207	8	500	450	550	0	18.5	5	M20×42
YE4-250M	FF500	4, 6, 8	406	80	349	168	65	140	18	58	250	24	490	565	405	655	985	450	30	207	8	500	450	550	0	18.5	5	M20×42
YE4-280S	FF500	2	457	85	368	190	65	140	18	58	280	24	550	635	445	725	995	480	35	215	8	500	450	550	0	18.5	5	M20×42
YE4-280S	FF500	4	457	85	368	190	75	140	20	67.5	280	24	550	635	445	725	985	480	35	215	8	500	450	550	0	18.5	5	M20×42
YE4-280M	FF500	2	457	85	419	190	65	140	18	58	280	24	550	635	445	725	1035	540	35	215	8	500	450	550	0	18.5	5	M20×42
YE4-280M	FF500	4	457	85	419	190	75	140	20	67.5	280	24	550	635	445	725	1035	540	35	215	8	500	450	550	0	18.5	5	M20×42
YE4-280M	FF500	6, 8	457	85	419	190	75	140	20	67.5	280	24	550	635	445	725	1035	540	35	215	8	500	450	550	0	18.5	5	M20×42
YE4-315S	FF600	2	508	120	406	216	65	140	18	58	315	28	630	645	535	850	1200	580	45	257	8	600	550	660	0	24	6	M20×42
YE4-315S	FF600	4, 6, 8, 10	508	120	406	216	80	170	22	71	315	28	630	645	535	850	1230	580	45	257	8	600	550	660	0	24	6	M20×42
YE4-315M	FF600	2	508	120	457	216	65	140	18	58	315	28	630	645	535	850	1310	680	45	257	8	600	550	660	0	24	6	M20×42
YE4-315M	FF600	4, 6, 8, 10	508	120	457	216	80	170	22	71	315	28	630	645	535	850	1340	680	45	257	8	600	550	660	0	24	6	M20×42
YE4-315L	FF600	2	508	120	508	216	65	140	18	58	315	28	630	645	535	850	1310	680	45	257	8	600	550	660	0	24	6	M20×42
YE4-315L	FF600	4, 6, 8, 10	508	120	508	216	80	170	22	71	315	28	630	645	535	850	1340	680	45	257	8	600	550	660	0	24	6	M20×42
YE4-315L2	FF600	2	508	120	508	216	65	140	18	58	315	28	630	645	535	850	1460	830	45	257	8	600	550	660	0	24	6	M20×42
YE4-315L2	FF600	4, 8, 10	508	120	508	216	80	170	22	71	315	28	630	645	535	850	1460	830	45	257	8	600	550	660	0	24	6	M20×42
YE4-355M	FF740	2	610	120	560	254	75	140	20	67.5	355	28	730	720	645	930	1505	760	52	284	8	740	680	800	0	24	6	M24×47
YE4-355M	FF740	4, 6, 8, 10	610	120	560	254	95	170	25	86	355	28	730	720	645	930	1535	760	52	284	8	740	680	800	0	24	6	M24×47
YE4-355L	FF740	2	610	120	630	254	75	140	20	67.5	355	28	730	720	645	930	1715	960	52	284	8	740	680	800	0	24	6	M20×42
YE4-355L	FF740	4, 6, 8, 10	610	120	630	254	95	170	25	86	355	28	730	720	645	930	1745	960	52	284	8	740	680	800	0	24	6	M24×47

注：1) R是法兰安装面至辅肩的距离。2) DH尺寸只有出口电机要求，国内用户应按订货要求进行配制。
3) D尺寸公差：φ19-28为j6；φ38-48为K6；φ55-80为m6；φ95为m6。4) N尺寸公差为j6。
Notes: 1) R means the distance from flange mounting interface surface to auxiliary shoulder. 2) DH dimension is only required for exported motor. For domestic customers, it should be prepared according to the order requirement.
3) Tolerance for D dimension: j6 for φ19-28; K6 for φ38-48; m6 for φ55-80; m6 for φ95. 4) Tolerance for N dimension is j6.

型号 Type	凸缘号 Flange NO.	极数 Poles	尺寸 Dimensions in mm															
			D*	E	F	G	M	N*	P	S	T	凸缘孔数 Flange holes	AC	L	LD	LA	(DH)*	R
YE4-80	FF105	2, 4, 6, 8	19	40	6	15.5	165	130	200	12	3.5	4	167	300	74	12	M6×16	0
YE4-90S	FF165	2, 4, 6, 8	24	50	8	20	165	130	200	12	3.5	4	190	355	76	12	M8×19	0
YE4-90L	FF165	2, 4, 6, 8	24	50	8	20	165	130	200	12	3.5	4	190	385	76	12	M8×19	0
YE4-100L	FF215	2, 4, 6, 8	28	60	8	24	215	180	250	14.5	4	4	215	435	83	13	M10×22	0
YE4-112M	FF215	2, 4, 6, 8	28	60	8	24	215	180	250	14.5	4	4	234	520	87	14	M10×22	0
YE4-132S	FF265	2, 4, 6, 8	38	80	10	33	265	230	300	14.5	4	4	296	510	102	14	M12×28	0
YE4-132M	FF265	2, 4, 6, 8	38	80	10	33	265	230	300	14.5	4	4	296	540	102	14	M12×28	0
YE4-160M	FF300	2, 4, 6, 8	42	110	12	37	300	250	350	18.5	5	4	330	670	146	15	M16×36	0
YE4-160L	FF300	2, 4, 6, 8	42	110	12	37	300	250	350	18.5	5	4	330	710	146	15	M16×36	0
YE4-180M	FF300	2, 4, 6, 8	48	110	14	42.5	300	250	350	18.5	5	4	365	735	161	15	M16×36	0
YE4-180L	FF300	2, 4, 6, 8	48	110	14	42.5	300	250	350	18.5	5	4	365	770	161	15	M16×36	0
YE4-200L	FF350	2, 4, 6, 8	55	110	16	49	350	300	400	18.5	5	4	418	870	186	17	M20×42	0
YE4-225S	FF400	4, 6, 8	60	140	18	53	400	350	450	18.5	5	8	464	890	189	20	M20×42	0
YE4-225M	FF400	2	55	110	16	49	400	350	450	18.5	5	8	464	895	189	20	M20×42	0
YE4-225M	FF400	4, 6, 8	60	140	18	53	400	350	450	18.5	5	8	464	925	189	20	M20×42	0
YE4-250M	FF500	2	60	140	18	53	500	450	550	18.5	5	8	520	985	207	22	M20×42	0
YE4-250M	FF500	4, 6, 8	65	140	18	58	500	450	550	18.5	5	8	520	985	207	22	M20×42	0
YE4-280S	FF500	2	65	140	18	58	500	450	550	18.5	5	8	583	995	215	22	M20×42	0
YE4-280S	FF500	4	75	140	20	67.5	500	450	550	18.5	5	8	583	995	215	22	M20×42	0
YE4-280S	FF500	6, 8	75	140	20	67.5	500	450	550	18.5	5	8	583	995	215	22	M20×42	0
YE4-280M	FF500	2	65	140	18	58	500	450	550	18.5	5	8	583	1035				

安装及外形尺寸 MOUNTING AND OVERALL DIMENSIONS

IM B34 H80-112

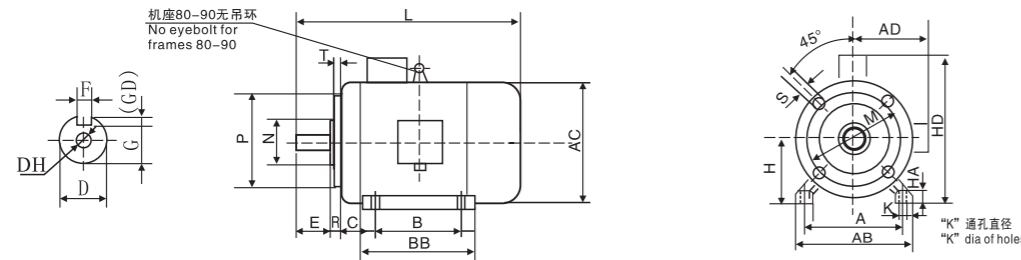

机座号 Prame Size	极数 Poles	安装尺寸 Mounting dimensions														凸缘孔数 Flange holes	外形尺寸 overall dimensions						
		A	B	C	D*	E	F	G	H	K	M	N*	P	R	S		T	AB	AC	AD	HD	L	(DH)*
YE4-80	2, 4, 6, 8	125	100	50	19	40	6	15.5	80	10	100	80	120	0	M6	3.0	4	165	167	165	245	300	M6×16
YE4-90S	2, 4, 6, 8	140	100	56	24	50	8	20	90	10	115	95	140	0	M8	3.0	4	180	190	175	250	355	M8×19
YE4-90L	2, 4, 6, 8	140	125	56	24	50	8	20	90	10	115	95	140	0	M8	3.0	4	180	190	175	250	385	M8×19
YE4-100L	2, 4, 6, 8	160	140	63	28	60	8	24	100	12	130	110	160	0	M8	3.5	4	205	215	200	270	435	M10×22
YE4-112M	2, 4, 6, 8	190	140	70	28	60	8	24	112	12	130	110	160	0	M8	3.5	4	230	255	223	335	520	M10×22

注：N尺寸公差为j6。 Notes: Tolerance for N dimension is j6.

安装及外形尺寸 MOUNTING AND OVERALL DIMENSIONS

IM B14 H80-112

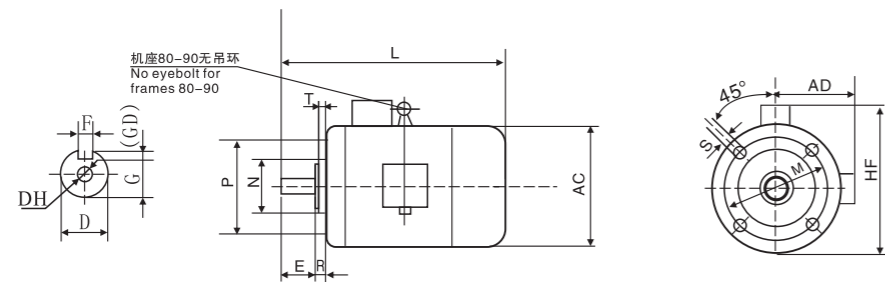

机座号 Prame Size	极数 Poles	安装尺寸 Mounting dimensions										凸缘孔数 Flange holes	外形尺寸 overall dimensions				
		D*	E	F	G	P	M	N	R	S	T		AD	AC	HF	L	(DH)*
YE4-80	2, 4, 6, 8	19	40	6	15.5	120	100	80	0	M6	3.0	4	165	167	230	300	M6×16
YE4-90S	2, 4, 6, 8	24	50	8	20	140	115	95	0	M8	3.0	4	175	190	245	355	M8×19
YE4-90L	2, 4, 6, 8	24	50	8	20	140	115	95	0	M8	3.0	4	175	190	245	385	M8×19
YE4-100L	2, 4, 6, 8	28	60	8	24	160	130	110	0	M8	3.5	4	200	215	285	435	M10×22
YE4-112M	2, 4, 6, 8	28	60	8	24	160	130	110	0	M8	3.5	4	223	255	355	520	M10×22

安装及外形尺寸 MOUNTING AND OVERALL DIMENSIONS

IMV1 H180-355

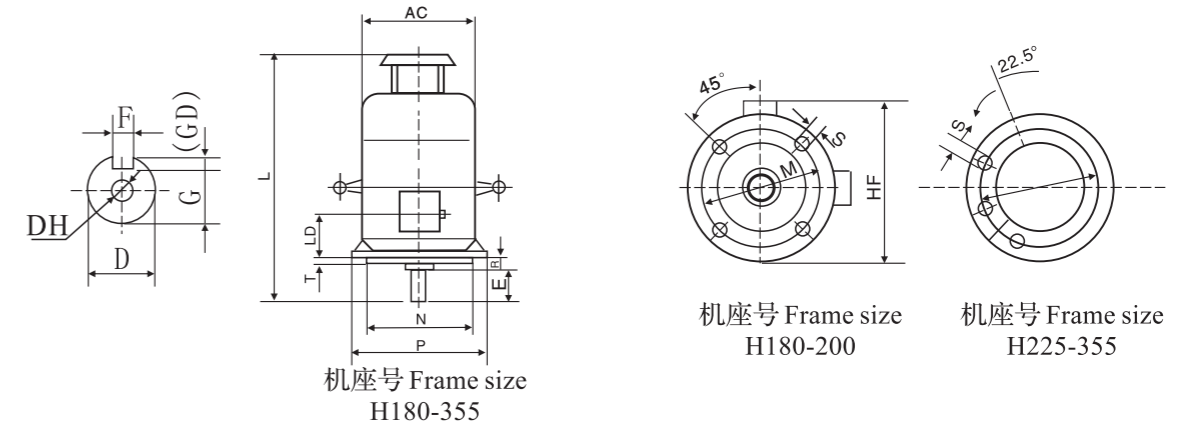

机座号 Prame Size	极数 Poles	安装尺寸 Mounting Dimensions										凸缘孔数 Flange holes	外形尺寸 Overall Dimensions				
		D*	E	F	G	M	N*	P	R	S	T		AC	AD	HF	L	(DH)*
YE4-180M	2, 4, 6, 8	48	110	14	42.5	300	250	350	0	18.5	5	4	365	295	470	795	M16×36
YE4-180L	2, 4, 6, 8	48	110	14	42.5	300	250	350	0	18.5	5	4	365	295	470	830	M16×36
YE4-200L	2, 4, 6, 8	55	110	16	49	350	300	400	0	18.5	5	4	418	340	540	940	M20×42
YE4-225S	4, 6, 8	60	140	18	53	400	350	450	0	18.5	5	8	464	370	595	980	M20×42
YE4-225M	2	55	140	16	49	400	350	450	0	18.5	5	8	464	370	595	985	M20×42
	4, 6, 8	60	140	18	53	400	350	450	0	18.5	5	8	464	370	595	1015	M20×42
YE4-250M	2	60	140	18	53	500	450	550	0	18.5	5	8	520	405	680	1090	M20×42
	4, 6, 8	65	140	18	58	500	450	550	0	18.5	5	8	520	405	680	1090	M20×42
YE4-280S	2	65	140	18	58	500	450	550	0	18.5	5	8	583	445	720	1110	M20×42
	4	75	140	20	67.5	500	450	550	0	18.5	5	8	583	445	720	1100	M20×42
	6, 8	75	140	20	67.5	500	450	550	0	18.5	5	8	583	445	720	1110	M20×42
YE4-280M	2	65	140	18	58	500	450	550	0	18.5	5	8	583	445	720	1150	M20×42
	4	75	140	20	67.5	500	450	550	0	18.5	6	8	583	445	720	1150	M20×42
	6, 8	75	140	20	67.5	500	450	550	0	18.5	6	8	583	445	720	1150	M20×42
YE4-315S	2	65	140	18	58	600	550	660	0	24	6	8	645	535	865	1320	M20×42
	4, 6, 8, 10	80	170	22	71	600	550	660	0	24	6	8	645	535	865	1350	M20×42
YE4-315M	2	65	140	18	58	600	550	660	0	24	6	8	645	535	865	1430	M20×42
	4, 6, 8, 10	80	170	22	71	600	550	660	0	24	6	8	645	535	865	1460	M20×42
YE4-315L1	2	65	140	18	58	600	550	660	0	24	6	8	645	535	865	1460	M20×42
	4, 6, 8, 10	80	170	22	71	600	550	660	0	24	6	8	645	535	865	1460	M20×42
YE4-315L2	2	65	140	18	58	600	550	660	0	24	6	8	645	535	865	1560	M20×42
	6	80	170	22	71	600	550	660	0	24	6	8	645	535	865	1560	M20×42
	4, 8, 10	80	170	22	71	600	550	660	0	24	6	8	645	535	865	1560	M20×42
YE4-355M	2	75	140	20	67.5	740	680	800	0	24	6	8	720	565	965	1645	M20×42
	4, 6, 8, 10	95	170	25	86	740	680	800	0	24	6	8	720	565	965	1675	M20×42
	2	75	140	20	67.5	740	680	800	0	24	6	8	720	565	965	1855	M20×42
YE4-355L	4, 6, 8, 10	95	170	25	86	740	680	800	0	24	6	8	720	565	965	1885	M24×47

注：1) DH尺寸只有出口电机要求，国内用户应按订货要求进行配制。

2) D尺寸公差：φ19-28为j6；φ38-48为K6；φ55-80为m6；φ95为m6。3) N尺寸公差为j6。

Notes: 1) DH dimension is only required for exported motor. For domestic customers, it should be prepared according to the order requirement. 2) Tolerance for D dimension: j6 for φ19-28; K6 for φ38-48; m6 for φ55-80; m6 for φ95.

3) Tolerance for N dimension is j6.

订货须知: INSTRUCTIONS TO BUYERS:

1) 本样本所提供的数据仅供用户参考，具体数据允许有变动，订货前请惠予联系。

The technical data given in this catalogue are for reference only and subject to alterations. Before ordering, please contact us.

2) 订货时请注明所需电动机产品型号、功率、同步转速、电压、频率和安装结构形式等。

The following specifications are provided for the order: motor type, output, synchronous speed, voltage, frequency and mounting arrangement etc.

此样本所有参数仅作参考选型用，如有变更，恕不奉告。